

“G20 the style Roger Technology is developed according to logic”

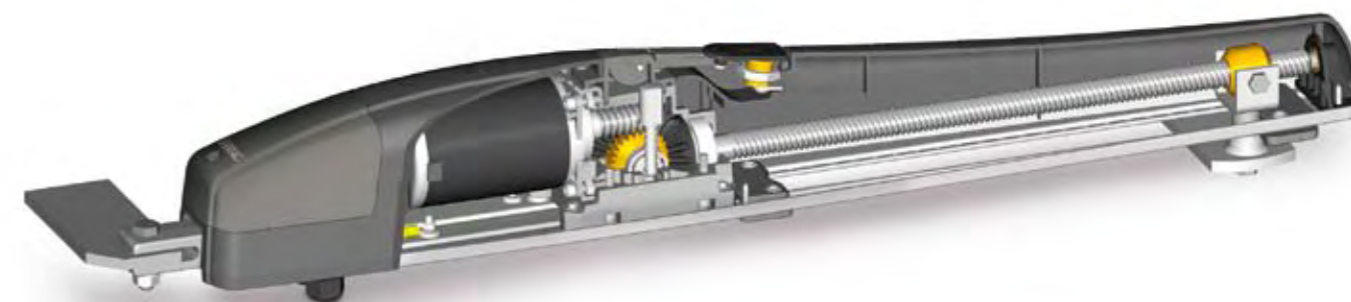

MODULAR SYSTEM IN IRRESISTIBLE COLOURS

Electromechanical gear motor, for swing gates. The main structure is made of aluminium. The cover is made of robust ABS available in a wide range of colours.

RANGE G20 VERSION

G20/330	230V • with mechanical opening stopper • optical encoder
G20/334	24V • with mechanical opening stopper • magnetic encoder

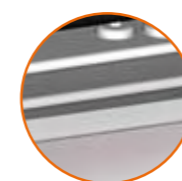

FREESTANDING STRUCTURE

The moulded aluminium base, to which all the components are fixed is extremely robust.

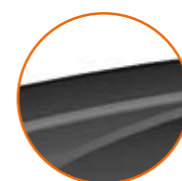

COLOURFUL ABS COVER

You can customise the cover by choosing from a wide range of colours. The thickness of the cover guarantees resistance to shocks.



MODULAR GEAR MOTOR

Choose between 220VAC and 24VDC motors, both of which are very powerful. Motor gear in bronze and bevel gear drive in steel.



MECHANICAL STOPPER

A robust mechanical opening stopper, that can be regulated with extreme precision.



FLUID, GRADUAL UNLOCKING

The unlocking handle has a customised key and can be manoeuvred manually with a gradual, fluid movement thanks to a spring system.



BRONZE "STEEL IS MY FAVOURITE"

The split nut performs the most important task of all, by transmitting energy to the gate motor. Created in bronze and coupled with the loose steel screw, it performs its function perfectly.



EASY ELECTRICAL CONNECTIONS

Professional intervention is made easy with easily-accessible electrical connections positioned in the upper part, protected by a robust coloured or enamelled shell.

G20		G20/330	G20/334			
POWER	V	230AC 50Hz	24DC			
POWER RATING	W	200	96			
VOLTAGE	A	1,1	4			
INTERMITTENCE	%	30	80			
MOTOR THERMAL PROTECTION	°C	140	-			
OPERATING TEMPERATURE	°C	-20+55	-20+55			
PROTECTION LEVEL	IP	43	43			
OPENING TIME FOR 90°	s	19	19			
SPEED	cm/s	1.66	1.66			
MAX THRUST	N	2500	2800			
TRAVEL	mm	310/340	310/340			

dimensions

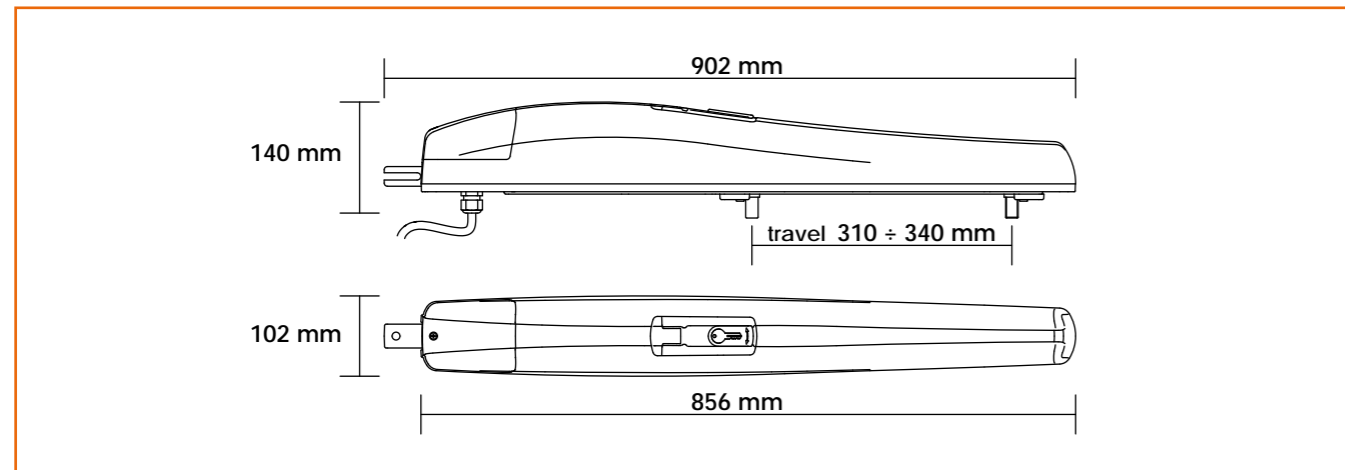

accessories

KT 201 long front bracket	KT 202 short front bracket	KT 203 long rear bracket	KT 204 short rear bracket
KT 205 3 long range bracket kit	KT 206 3 short range bracket kit	MC 779 mechanical stopper kit for closure	